

This guide provides information on the Rotate, Scale, and Justify functions available in the Z Print software. Properly oriented models reduce the likelihood of encountering problems during the build process. Rotating models can provide better surface finish, reduce build time, and minimize model deformation. There are times when a model will need to be scaled to reduce or enlarge its dimensions for specific applications. If the model is too large to build as one piece, it may be split and reassembled. Properly justifying models may reduce build time and create better fitting assemblies.

Refer to the Z Print Software Manual for additional information on how to use the orientation functions.

## Legend

The colors in this legend correspond with specific processes on the inside pages.

- **Rotate Function**  
Rotating models for speed and surface finish.
- **Scale Function**  
Scaling models to show detail or to fit in build area.
- **Splitting Models**  
Split large models and build as multiple pieces.

## Equipment

- Computer
- Z Print Software
- CAD Software

## Environment

Classroom, Office, or Computer Lab

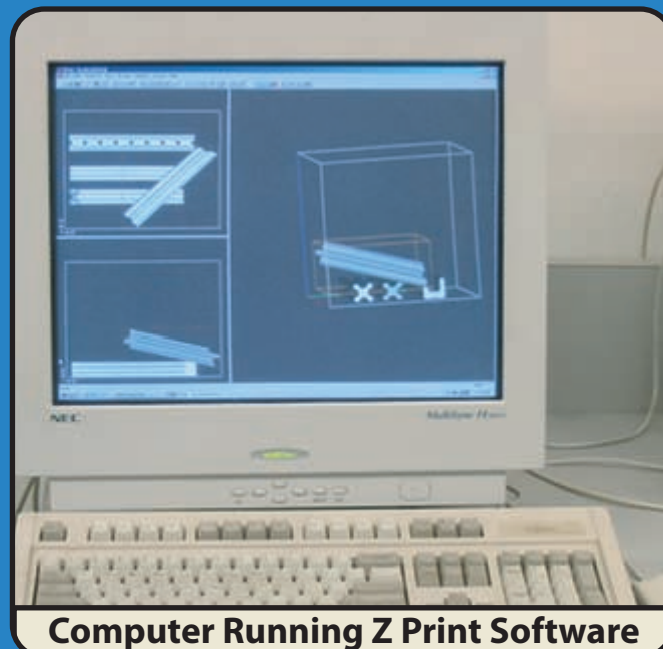

Computer Running Z Print Software

Z Corporation  
Z®Print Software



## Definition

**scale** - A proportion used in determining the dimensional relationship of a representation to that which it represents.

# About Z Corporation

Z Corporation manufactures office-compatible 3D printers that quickly and inexpensively produce real physical models directly from digital data. The 3D Printers use ink-jet printing technology to deposit a binder onto a powder, building the parts layer by layer. The finished parts are exact representations of the design created in CAD or other digital data. These models can be handled, reviewed and exchanged to enhance communication in the product design and development process. 3D Printers are used in a broad range of industries including automotive, defense, consumer products, electronics, architecture, medical, and geographic information systems.



z corporation

# Orientation Tips

## Model Layout and Splitting

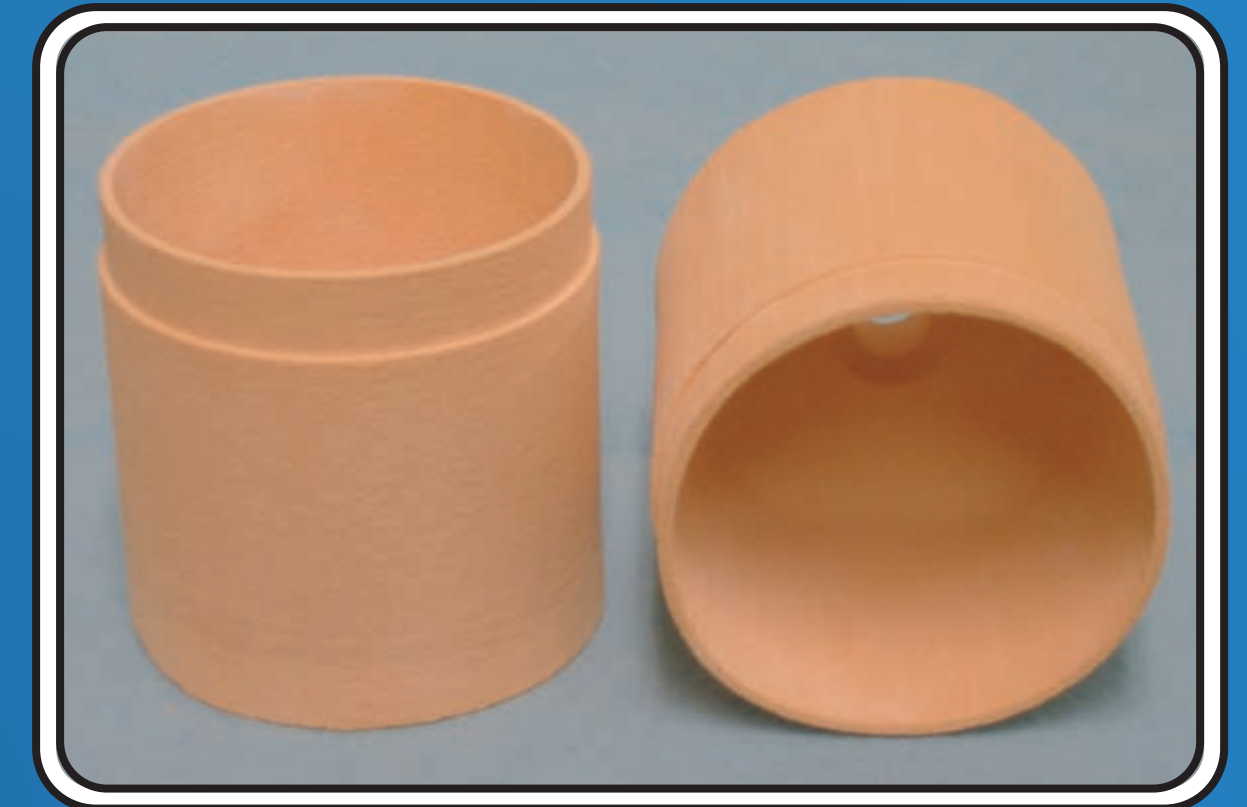

Technician Education in Rapid Prototyping and  
Virtual Manufacturing Technologies

[www.rpttechnologies.com](http://www.rpttechnologies.com)

© 2004 RP Technologies. All Rights Reserved.



1

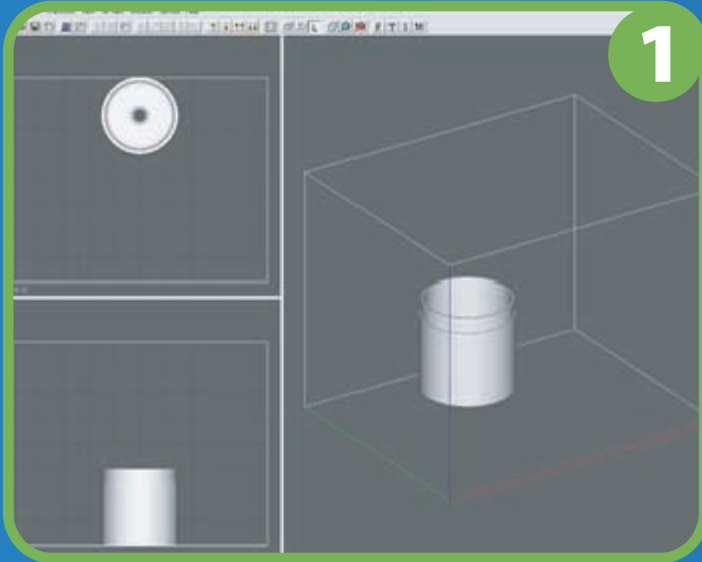

### Rotate: Vertical

Rotating models so they are oriented vertically in the build area will provide a smoother surface finish. Thin wall models should be rotated to build vertically.

The Rotate function is located on the Transform menu in the Z Print software.

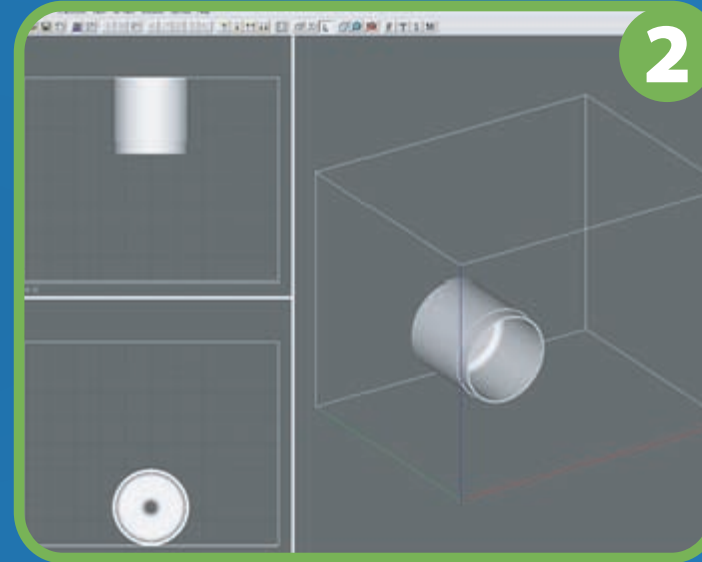

### Rotate: Horizontal

Building a model horizontally will generally lower the build time, however this often results in a rough surface finish. Be careful when building thin wall models horizontally as they may deform.

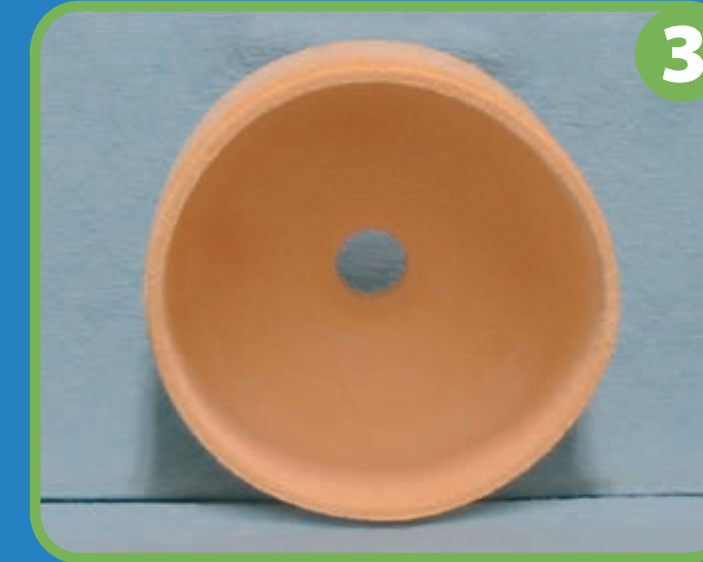

### Rotate: Deformation

If the model has walls 1/8th of an inch or less, the model may deform when being built horizontally. Thin wall models are unable to hold the weight of the support material. Deformation is more often seen when building round models.

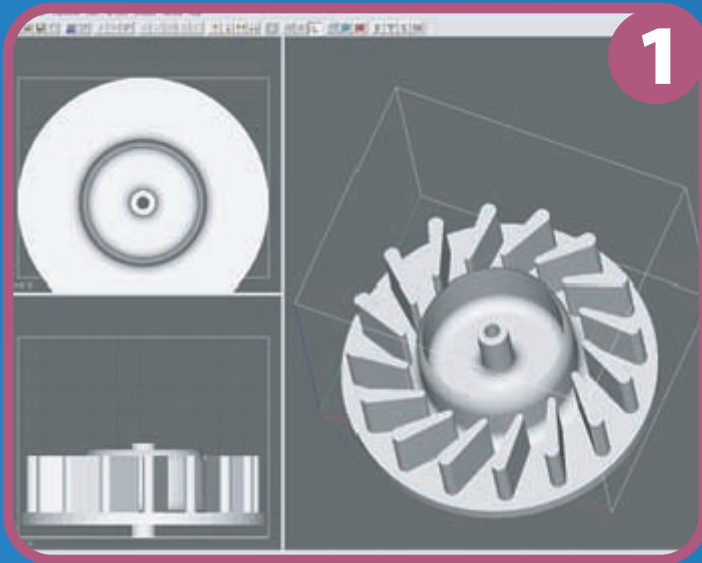

### Scale

Some models may need to be scaled before building. Scaling a model increases or decreases its dimensions. A model may be scaled by a percentage or by an X, Y, or Z dimension.

The Scale function is located on the Transform menu in the Z Print software.

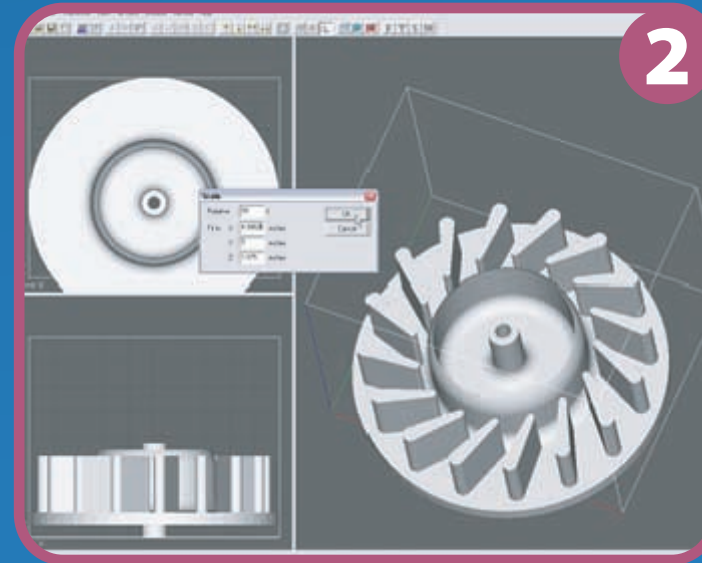

### Scale: Enlarge

The most common way to enlarge a model is to scale it by a percentage larger than 100%. Enlarged or "oversized" models are useful to show details and features of a very small object.

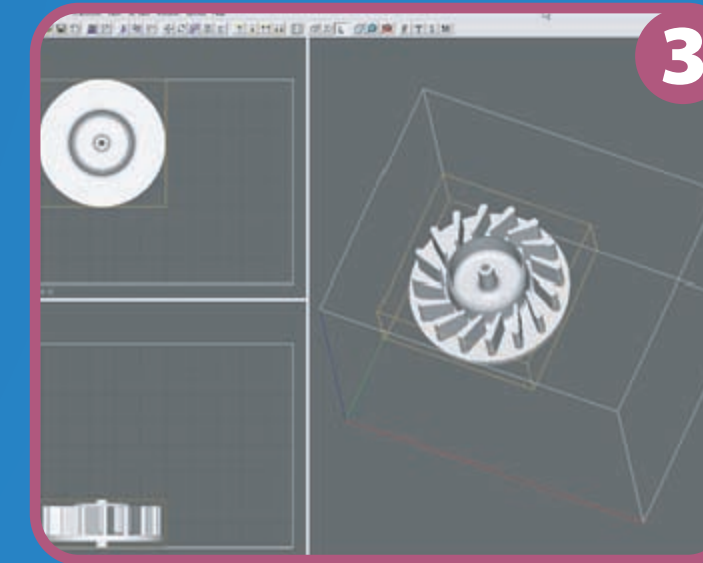

### Scale: Reduce

When a model is too large for the build area, it will need to be scaled down or split into pieces. Reducing a model is typically done by scaling it to a percentage less than 100%.

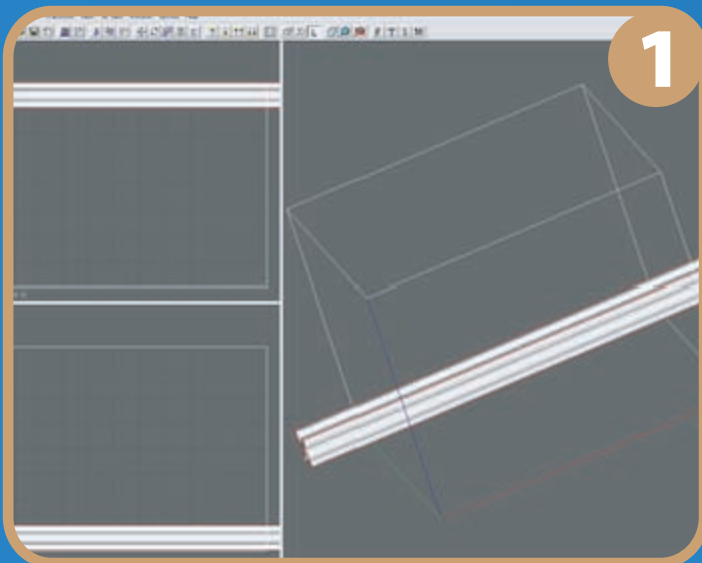

### Splitting Models

If a model needs to be built full scale and does not fit in the build area it needs to be split. Most CAD programs are capable of splitting models into smaller pieces and exporting each piece as a separate file.

Each piece needs to be imported separately and properly oriented.

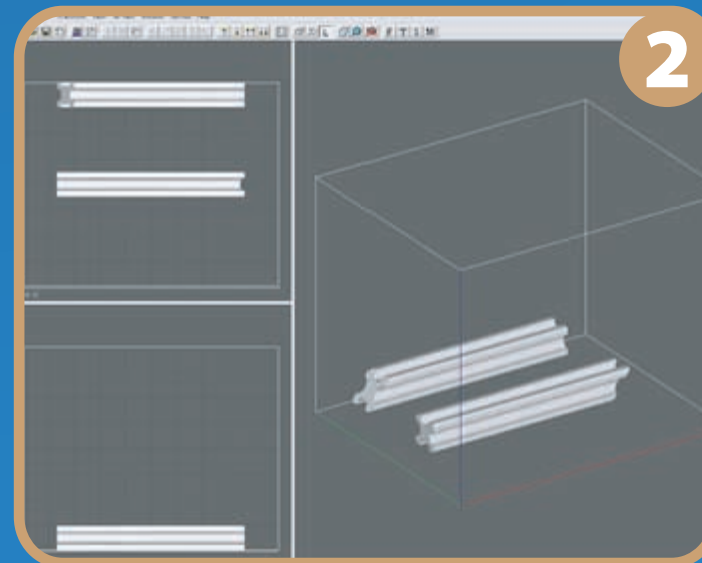

### Splitting: Import/Justify

Models with multiple pieces should be justified to the same plane. This will allow for easier reassembly. Justifying models may also reduce build time. Justifying to the Left/Back/Bottom is recommended.

The Justify function is located on the Transform menu in the Z Print software.

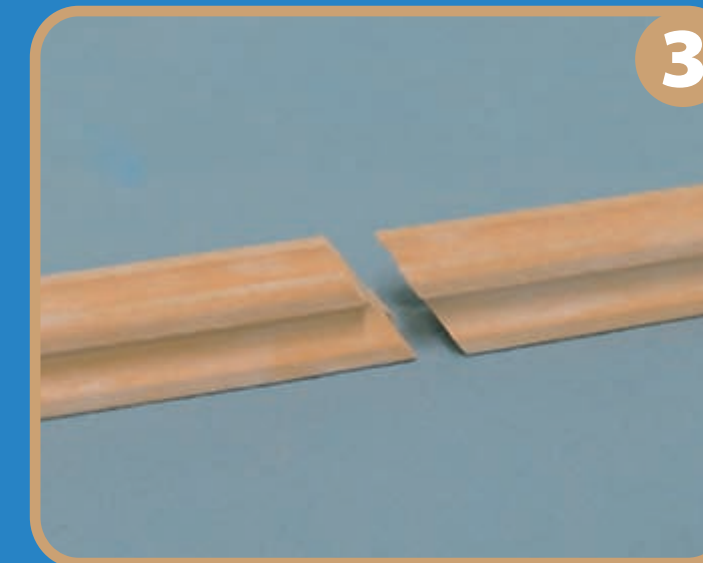

### Splitting: Assembly

A multi-piece model should not be infiltrated or post processed until it has been assembled. The process of assembling a multi-piece model is covered in detail in IG-6 "Model Assembly and Preparation".